

MecSoft Corporation  
Your CAM Partner

MecSoft

# VisualCAM 2016

*Computer Aided Manufacturing for everyone!*

Powerful | Easy To Learn | Easy To Use | Value Priced



## VisualCAM®

*VisualCAM includes VisualMILL, VisualTURN, VisualNEST & VisualART.  
A complete CNC programming system for rapid prototyping, mold & die, tooling,  
wood working, general machining, hobby & education.*

Also available as plug-ins to Rhino® and SolidWorks®

VisualMILL includes powerful 2.5, 3, 4 and 5 axis machining functionality to program CNC mills. Comes with hundreds of free post-processors and the ability to create new ones.

VisualTURN is a complete 2 axis CNC turning center programming system, including Roughing, Finishing, Grooving and other machining methods as well as free post-processors.

VisualNEST with both Rectangular & True Shape nesting is used for optimally arranging and fitting arbitrary part geometry shapes onto sheets of stock material.

VisualART converts artwork to geometry suitable for machining. Used for modeling artistic shapes using bitmap images, it extends the capabilities of the machining modules.

# VisualMILL 2016

VisualMILL is one of the 4 modules in the VisualCAD/CAM standalone product suite that is used for programming CNC mills. It is ideal for rapid-prototyping, mold & die, tooling, wood working, general machining, hobby and education. VisualMILL includes 2.5, 3, 4 and 5 axis machining functionality. It comes with hundreds of free post-processors and a post-processor generator to create your own. Priced right for the cost conscious buyer, VisualMILL software delivers outstanding value for your investment.



## Configurations

### VisualMILL Xpress (XPR)

A program tailored for hobbyists, makers and students. Ideal for getting started with CAM programming. Includes 2 & 3 axis machining methods.

### VisualMILL Professional (PRO)

For demanding users with sophisticated requirements such as mold, die & tooling, woodworking industries. Includes all of EXP plus indexed 5 axis machining and advanced 3 axis machining methods.

### VisualMILL Standard (STD)

A multi-purpose program suited for production, rapid prototyping, flat panel & general machining, where ease of use and a complete tool set is important. Includes 2 & 3 axis machining methods and advanced simulation.

### VisualMILL Expert (EXP)

Includes all of STD functionality plus a wider range of 2, 3 axis methods as well as 4 axis Indexed and continuous roughing and finishing operations and advanced simulation.

### VisualMILL Premium (PRE)

For demanding users with highly sophisticated manufacturing requirements such as aerospace, advanced mold making and woodworking. All of PRO functionality plus continuous 5 Axis machining.

2 1/2-Axis Milling	XPR	STD	EXP	PRO	PRE
Pocketing	●	●	●	●	●
Profiling	●	●	●	●	●
Facing	●	●	●	●	●
Engraving	●	●	●	●	●
Bridges/Tabs	●	●	●	●	●
2-Axis Roughing	●	●	●	●	●
High Speed Pocketing	●	●	●	●	●
V-Carving	●	●	●	●	●
V-Carve Roughing	●	●	●	●	●
Chamfering	●	●	●	●	●
Hole Making	●	●	●	●	●
T-Slot Milling	●	●	●	●	●
Thread Milling	●	●	●	●	●
Re-Machining	●	●	●	●	●
3 Axis Milling	XPR	STD	EXP	PRO	PRE
Horizontal Roughing	●	●	●	●	●
Parallel Finishing	●	●	●	●	●
Horizontal Finishing	●	●	●	●	●
Radial Machining	●	●	●	●	●
Spiral Machining	●	●	●	●	●
Clear Flats Machining	●	●	●	●	●
Plunge Roughing	●	●	●	●	●
Horizontal Re-roughing	●	●	●	●	●
Plunge Re-roughing	●	●	●	●	●
Projection Pocketing	●	●	●	●	●
3D Offset Profiling	●	●	●	●	●
3D Offset Pocketing	●	●	●	●	●
Pencil Tracing	●	●	●	●	●
Valley Re-Machining	●	●	●	●	●
Plateau Machining	●	●	●	●	●
Steep Area Parallel Machining	●	●	●	●	●
Horizontal Hill Machining	●	●	●	●	●
Curve Machining	●	●	●	●	●
Between 2 Curves Machining	●	●	●	●	●
Reverse Post Machining	●	●	●	●	●

4 Axis Milling	XPR	STD	EXP	PRO	PRE
4 Axis Indexed Machining	●	●	●	●	●
4 Axis Auto Multiple Indexing	●	●	●	●	●
4 Axis Continuous Facing	●	●	●	●	●
4 Axis Continuous Pocketing	●	●	●	●	●
4 Axis Continuous Profiling	●	●	●	●	●
4 Axis Continuous Engraving	●	●	●	●	●
4 Axis Parallel Roughing	●	●	●	●	●
4 Axis Parallel Finishing	●	●	●	●	●
4 Axis Radial Finishing	●	●	●	●	●
4 Axis Projection Pocketing	●	●	●	●	●

5 Axis Milling	XPR	STD	EXP	PRO	PRE
5 Axis Indexed Machining	●	●	●	●	●
5 Axis Curve Projection Machining	●	●	●	●	●
5 Axis Flow Curve Machining	●	●	●	●	●
5 Axis Between 2 Curves Machining	●	●	●	●	●
5 Axis Drive Curve Machining	●	●	●	●	●
5 Axis Surface Normal Machining	●	●	●	●	●
5 Axis Swarf Machining	●	●	●	●	●

Hole Making	XPR	STD	EXP	PRO	PRE
Automatic Hole Selection	●	●	●	●	●
Drilling	●	●	●	●	●
Tapping	●	●	●	●	●
Boring	●	●	●	●	●
Reverse Boring	●	●	●	●	●
User Defined Cycles	●	●	●	●	●
4 Axis Drilling	●	●	●	●	●
4 Axis Tapping	●	●	●	●	●
4 Axis Boring	●	●	●	●	●
4 Axis Reverse Boring	●	●	●	●	●

Simulation	XPR	STD	EXP	PRO	PRE
Toolpath Animation	●	●	●	●	●
Cut Material Simulation	●	●	●	●	●
Advanced Cut Material Simulation	●	●	●	●	●
Machine Tool Simulation	●	●	●	●	●

Tools	XPR	STD	EXP	PRO	PRE
Standard (Ball, Flat, C Rad., Vee, Drill)	●	●	●	●	●
Advanced (Taper, Tap, Bore, Rev. Bore)	●	●	●	●	●
Form Tools	●	●	●	●	●
Stepped Tools	●	●	●	●	●
Holder Collision Detection	●	●	●	●	●

Toolpath Editing	XPR	STD	EXP	PRO	PRE
Toolpath Graphical Viewing	●	●	●	●	●
Toolpath Graphical Editing	●	●	●	●	●
Toolpath Instancing	●	●	●	●	●
Toolpath Arc Fitting	●	●	●	●	●

Post Processor Generator	XPR	STD	EXP	PRO	PRE
Customizable Post Generator	●	●	●	●	●
Simulate Cycles	●	●	●	●	●
Arc Output	●	●	●	●	●
Helix Output	●	●	●	●	●
Spiral Output	●	●	●	●	●
5 Axis Output	●	●	●	●	●

Miscellaneous	XPR	STD	EXP	PRO	PRE
32 & 64 Bit	●	●	●	●	●
HTML Shop Documentation	●	●	●	●	●
Avoid Regions	●	●	●	●	●
Knowledge Base	●	●	●	●	●
Default Knowledge Base	●	●	●	●	●
Machine Control Operations	●	●	●	●	●
Predefined Regions	●	●	●	●	●
Explode Cabinet Model	●	●	●	●	●
Rotate Table Setups	●	●	●	●	●
Multiple Setups	●	●	●	●	●
Fixture Offset Programming	●	●	●	●	●
Check Surface Boundary Creation	●	●	●	●	●
Tool Silhouette Boundary Creation	●	●	●	●	●
Tool Double Contact Boundary Creation	●	●	●	●	●
Tool Holder Collision Boundary Creation	●	●	●	●	●

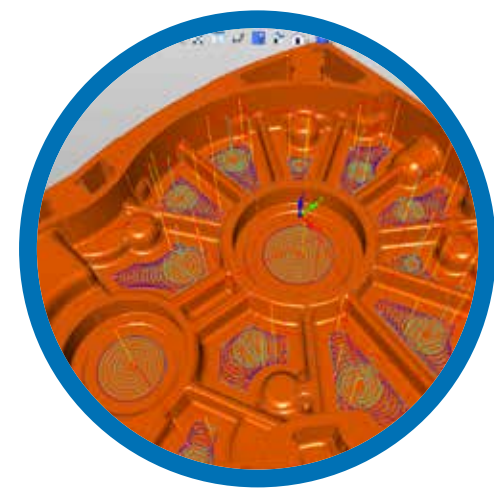

## VisualTURN 2016

VisualTURN is a powerful 2 axis turning center/lathe programming system, that is included as a separately licensed module inside VisualCAM. This module includes Turn Roughing, Finishing, Groove Roughing, Finishing, Threading, Parting, Hole Machining methods & free post processors.



2 Axis Turning	VisualTURN
Roughing	●
Finishing	●
Groove Roughing	●
Groove Finishing	●
Threading	●
Follow Curve	●
Parting Off	●
Upgraded 3D Model Slicing	●
Global Part Object	●
Materials for Stock Models	●
Knowledge Base Loading and Saving	●
Tool Path Viewer	●
MopSets	●
Machine Control Operations	●
Fixture Offset Operations	●
Drag and drop operations from Knowledge Base	●
Diameter Programming	●

Hole Making	VisualTURN
Drilling	●
Tapping	●
Boring	●
Reverse Boring	●

Toolpath Simulation	VisualTURN
Toolpath Animation	●
Cut Material Simulation	●
Part to Stock Comparison	●

Post-Processor Generator	VisualTURN
User customizable post-processor generator	●

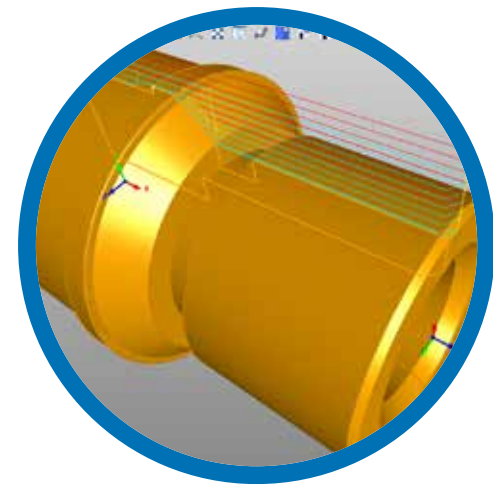

## VisualNEST 2016

VisualNEST is a cost effective solution for optimally arranging and fitting geometric shapes onto sheets of stock or sheet material. It provides two primary nesting capabilities: Rectangular Nesting and True Shape Nesting. For both solutions, individual 2D CAD shapes can be arranged on sheets according to user-defined quantities, spacing, and with orientation control, including material grain restrictions.



*Rectangular Nesting* is very fast and useful in cases where the shapes are rectangular, such as when nesting panels for the assembly furniture industry.

*True Shape Nesting* considers the true shape of the parts to be nested and can place smaller parts within cutouts of larger parts and can also accept true shape remnants as material sheets. Resultant nested geometry can be saved and utilized in down-stream such as machining or fabrication.

User Interface Enhancements	VisualNEST
Wizard Interface	●
Preview before output	●

Nesting Methods	VisualNEST
Rectangular/Block Nesting	●
True Shape Nesting	●

Global Parameters	VisualNEST
Distance limits between part and sheet	●
Distance limits between two adjacent parts	●
Accuracy control of nesting	●

Sheet Parameters	VisualNEST
Sheet start corner	●
Nesting direction	●
Grain direction	●
Unlimited number of sheets	●
Sheet layering by color	●

Part Parameters	VisualNEST
Distance limits between part and part	●
Rotation limits	●
Mirroring	●
Island recognition	●
Part-in-Part	●

Miscellaneous	VisualNEST
Tagging of parts	●
Nesting for cabinet making	●
Nesting for sign making	●

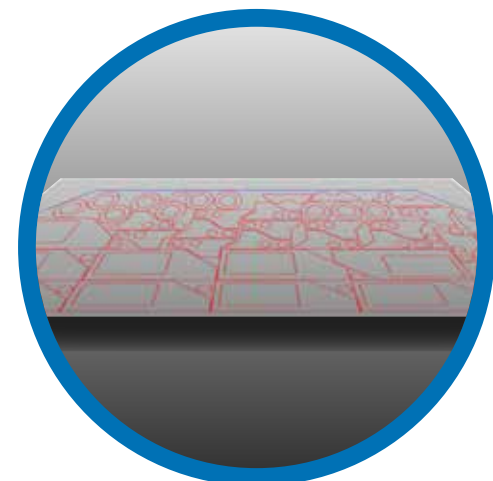

# VisualART 2016

VisualART is a module within VisualCAD/CAM product suite used to convert artwork into geometry suitable for machining. It uses special modeling techniques for modeling artistic shapes using raster bitmap images. Used in conjunction with VisualCAD's modeling tools, it offers a complementary set of modeling techniques for jewelry design, sign making and model making.



Feature	VisualART
Create 3D Relief from bitmap image files	●
Ability to limit creation of reliefs using colors and/or curves	●
Create puffed up 3D volumes using closed curves	●
Create 3D sweep volumes using various profiles	●
Combine 3D volumes using various Boolean operations during creation	●
Export created 3D volumes as Mesh geometry to CAD system	●
Convert 3D CAD geometry to ART 3D volumes	●
Create 2D Curve geometry from image files using Raster to Vector operations	●
All operations are associative to CAD geometry used in creation	●
Save and reuse previously created 3D volumes using Shape Library functionality	●

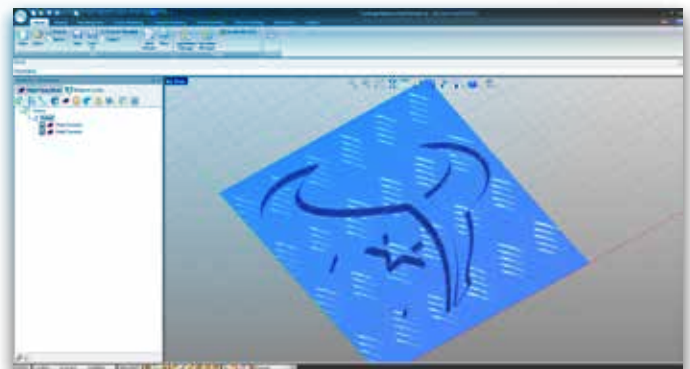
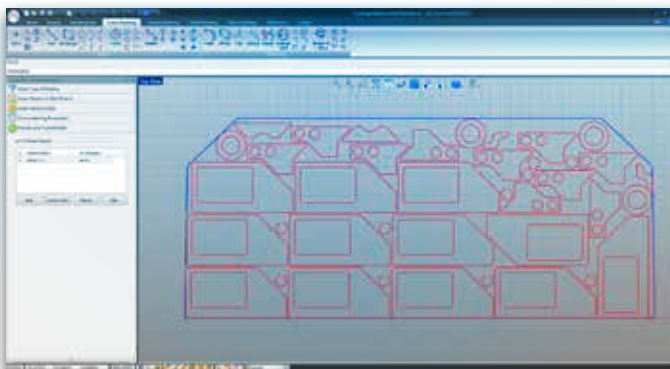
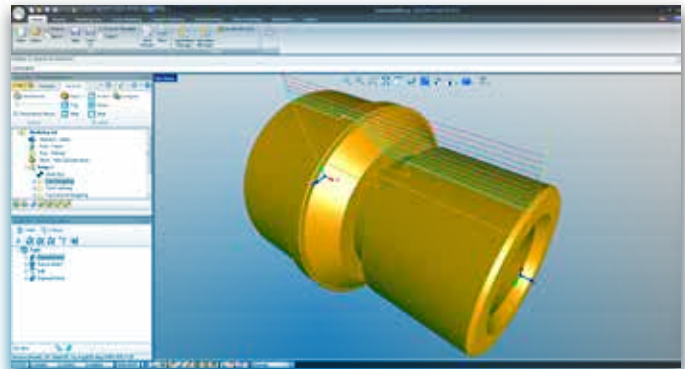
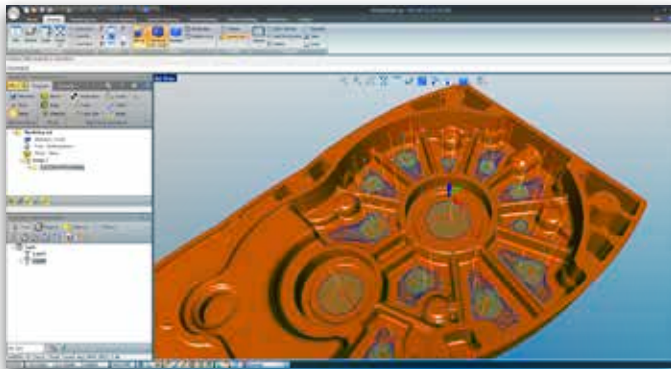

## System Requirements

- Runs on both 32 bit and 64 bit versions of VisualCAD
- CPU: Pentium class or higher processor
- RAM: Minimum: 1GB, Recommended: 4GB or higher
- Disk: 700 MB of free disc space
- OS: Microsoft Windows 7, 8 & 10
- Graphics: Requires OpenGL, Recommended OpenGL 2

## Other

- [Free Technical Support](#)
- [Training](#)
- [Support Forum](#)
- [Maintenance Services](#)
- [Value Pricing](#)